

STEC RP SERIES RIPPER

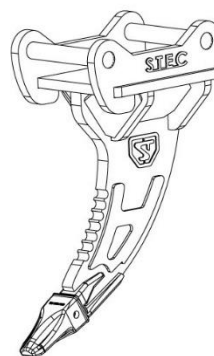
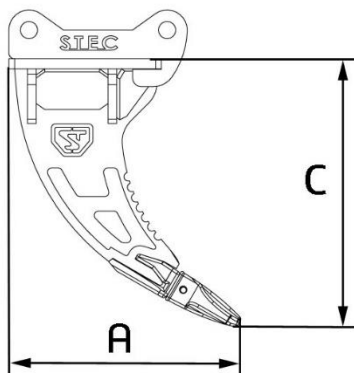
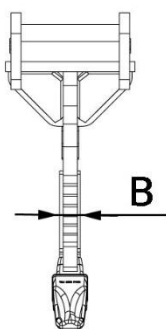

MACHINE WEIGHT	PRODUCT CODE	LENGTH (A)	WIDTH (B)	HEIGHT (C)	WEIGHT	ATTACHMENT		TEETH 4 pcs
						Direct boom	S-Standard	ESCO ultralock / CAT J
5-8 t	STEC RP 08	690	59	775	170	yes	S45	U25 / J250
8-12 t	STEC RP 12	720	64	860	180	yes	S50	U25 / J250
10-16 t	STEC RP 16	800	72	930	290	yes	S60	U35 / J350
16-21 t	STEC RP 21	910	82	1040	440	yes	S70	U35 / J350
21-28 t	STEC RP 24	1010	90	1150	510	yes	S70	U45 / J450
28-36 t	STEC RP 30	1120	100	1300	770	yes	S80	U55 / J550
30-40 t	STEC RP 40	1170	120	1380	850	yes	S80	U55 / J550
40-50 t	STEC RP 50	1320	140	1480	1380	yes	S90	U65 / J650